

FULL FUNCTION KEYBOARD CONTROLLER

GS-KBC6

USER MANUAL



GOLDEN STATE INSTRUMENT CO.

14256 Doolittle Drive, San Leandro, CA 94577



(510)352-7860 Fax(510)352-5988

Email:gsi@goldenstateinst.com

Website:www.goldenstateinst.com

1-800-227-2330

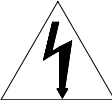
SAFETY PRECAUTIONS

	CAUTION RISK OF ELECTRIC SHOCK. DO NOT OPEN!	
CAUTION: TO REDUCE THE RISK OF ELECTRICAL SHOCK, DO NOT OPEN COVERS. NO USER SERVICEABLE PARTS INSIDE. REFER SERVICING TO QUALIFIED SERVICE PERSONNEL		

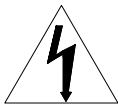

The lightning flash with a arrowhead symbol, in an equilateral triangle, is intended to alert the user. There is uninsulated “dangerous voltage” presence near by the product’s enclosure which may be risk of to persons .



The exclamation point within an equilateral triangle is intended to alert the user to reference of the important operating and maintenance (servicing) instructions .

THE PRODUCT CODE MARKED ON THE BOTTOM COVER. PLEASE FILL THE CODE IN THE FOLLOWING BLANK. PLEASE SAVING THIS SPECIFICATION CAREFULLY, SO THAT CHECKING.

MODEL: _____

PRODUCT CODE: _____

INDEX

I. Summary	-----2
II. Introduction of Functions	-----3
III. Introduction of the Keyboard Panel	-----3
➤ The Sketch of the Front Panel and Description of Buttons	-----3
➤ Rear Panel	-----5
IV. Setting of the Keyboard	-----5
➤ 4.1 Setup of the Protocol and the Default Baud Rate	-----5
➤ 4.2 Setup of the Baud Rate of Communication	-----6
V. Operation of the Keyboard	-----6
VI. Installation and Connection	-----8
VII. Technical Specifications	-----9
VIII. Points for Attention	-----10

I. Summary

The keyboard controller is used for terminal receivers such as the intelligent speed dome and the decoder etc. Taking the EIA/RS-485 electrical interface between the keyboard and the receiver, one keyboard can control as much as 32 speed dome and decoders without driving the bus and the maximum communication distance between the keyboard and the receiver is up to 1.2 km. It is very easy for operating and setting the speed dome camera. The controller is also to control the terminal receiver to achieve the function of controlling pan/tilt, lens and etc.

Main Functions:

- ◆ Set the address range of the dome camera and the decoder: 0~255.
- ◆ To directly control full functions of speed dome camera. For example: turn ON/OFF camera BLC.
- ◆ To operate the pan/tilt of speed dome camera moving in different speed level
- ◆ To set up 128 preset positions and 6 cruising tracks for speed dome camera and call any of them. Each cruising track contains up to 16 preset positions. You can set up the staying period and moving speed for each preset position.
- ◆ To control speed dome camera by manual/auto operation. It is possible to change the initial set through setting the speed dome camera menu.
- ◆ Manually control the focus, zoom and iris of the camera.

II. Introduction of Functions

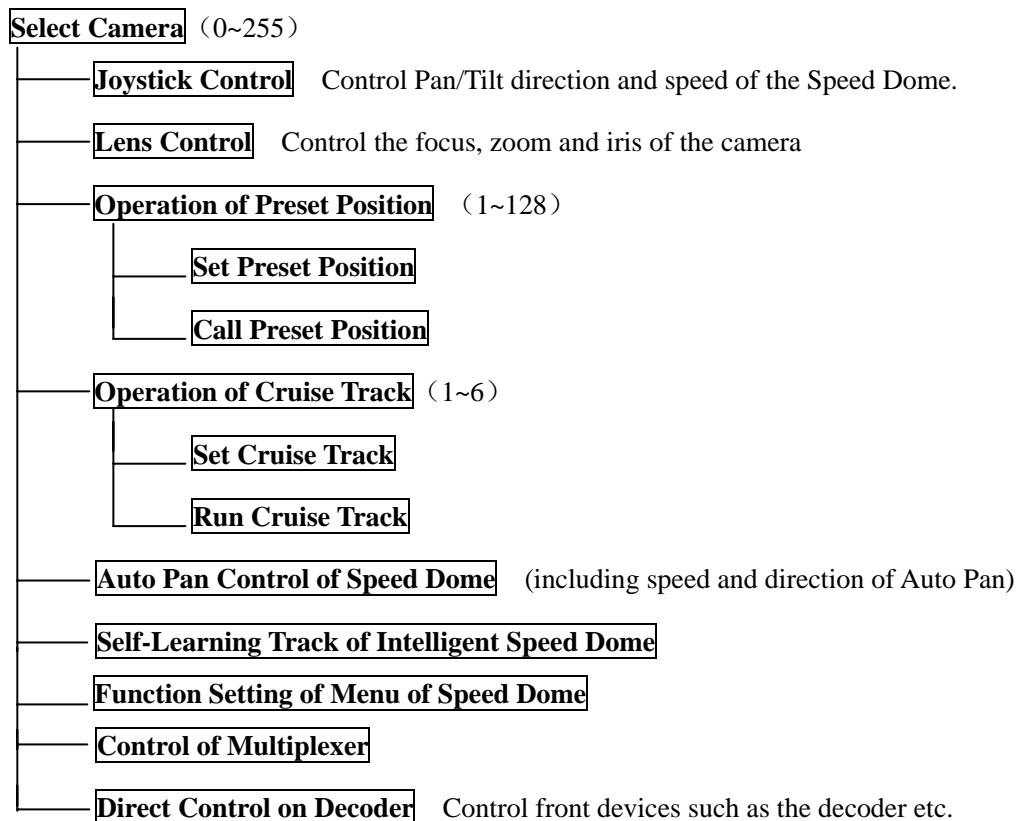

III. Introduction of the Keyboard Panel

1. The Sketch of the Front Panel and Description of Buttons (Figure 1)

There are speed joystick, buttons and LCD on the front panel of the control keyboard. The display is used to show the status of the system as well as operation information. The joystick controls the upward, downward, leftward and rightward speed motion of the speed dome. The description of buttons is as follows:

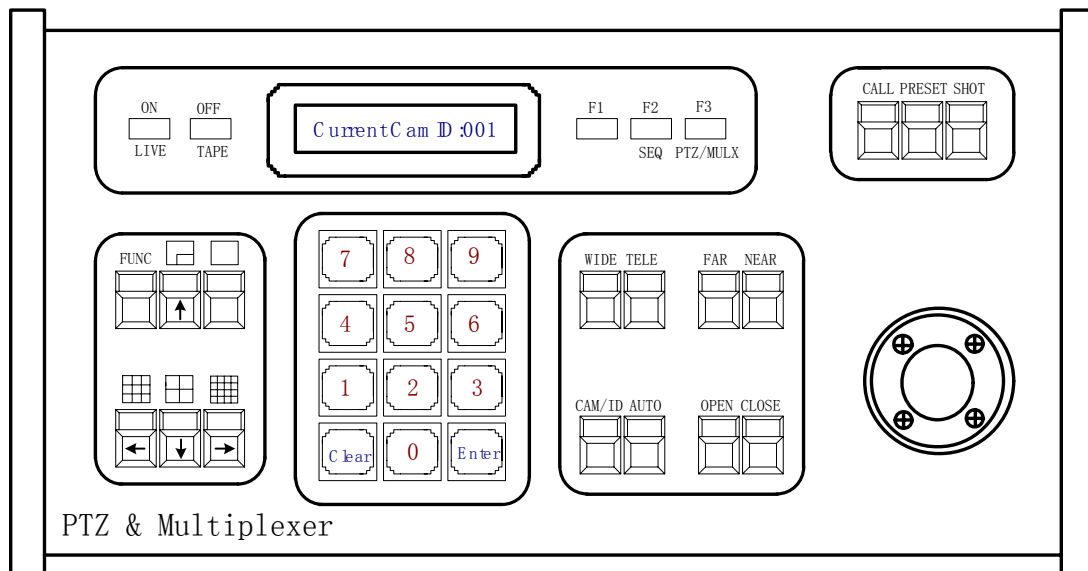

(Figure 1)

- **Func (1 cam):** Set special function of the system together with other buttons.
- **Zoom (Full screen):** Show picture of the camera in full screen. Press **Zoom** again to review a 2 Zoom of the selected camera.
- **PIP (up arrow):** Show picture of the camera in PIP mode (Picture-in-Picture).
- **2×2 (down arrow):** Show picture of the camera in 4-frame.
- **3×3 (left arrow):** Show picture of the camera in 9-frame.
- **4×4 (right arrow):** Show picture of the camera in 16-frame.
- **Live:** Show live picture of the camera at current mode.
- **Tape:** Playback pictures; **Function + Tape:** Playback video information of VCR.
- **CAM: in multiplexer mode:** Used with camera buttons to select cameras to display in the full, PIP, 2×2, 3×3, 4×4 formats. **in speed dome mode :** Select address of the intelligent speed dome.
- **F2: in multiplexer mode:** Start automatic switching of cameras. This button is also used during setup to turn on all motion detection targets. **in speed dome mode :** Auxiliary control buttons.
- **CALL:** To call the preset position.
- **PRESET:** To set the preset position.
- **SHOT:** To set up or call cruising track.
- **AUTO:** To control auto-horizontal rotation for pan/tilt.
- **WIDE:** To a wide angle.
- **TELE:** To turn to a telescopic range.
- **FAR:** To make focus far manually.
- **NEAR:** To make focus near manually.
- **OPEN:** To open iris.
- **CLOSE:** To close iris.
- **ON:** Switch on the setting of function.
- **OFF:** Switch off the setting of function.
- **F1:** Auxiliary control buttons.
- **F3:** Switching control between intelligent speed dome and multiplexer.
- **[0]-[9]:** Number key
- **[Clear]:** To clear inputted data
- **[Enter]:** To confirm

2. Rear Panel (Figure 2)

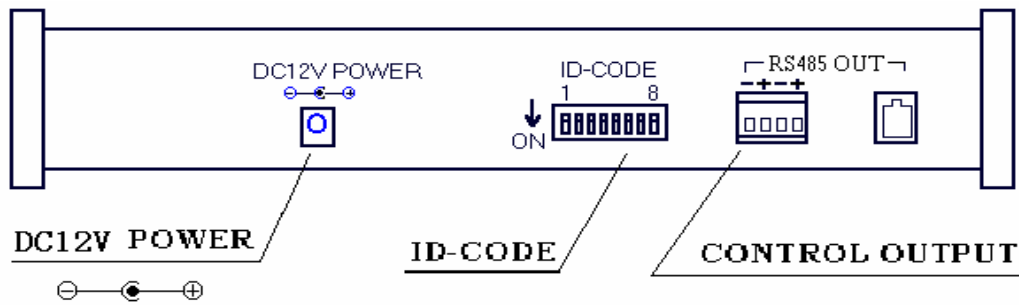

(Figure 2)

- A. Power input connector: input DC12V power.
- B. ID-Code switch: Used to set the protocol in use and the baud rate of communications.
- C. Communication connector RS485: The controller is connected to adapter box by specific cable.

IV. Setting of the Keyboard

- a) The protocol in use and the baud rate of communication of the keyboard are set by the ID-CODE in Figure 2. DIP1-DIP4 are used to select type of the communication protocol as per following table:

Protocols	DIP status				Normal Baud Rate	
	DIP-1	DIP-2	DIP-3	DIP-4	DIP-5	DIP-6
COP-2	ON	OFF	OFF	OFF	OFF	ON
Santachi	OFF	ON	OFF	OFF	OFF	ON
PELCO-D	ON	ON	OFF	OFF	OFF	OFF
PELCO-P/4800	OFF	OFF	ON	OFF	ON	OFF
PELCO-P/9600					OFF	ON
PANASONIC	ON	OFF	ON	OFF	OFF	ON
Reserved	OFF	ON	ON	OFF	OFF	ON
HUNDA600	ON	ON	ON	OFF	OFF	ON
LILIN	OFF	OFF	OFF	ON	OFF	ON
Reserved	ON	OFF	OFF	ON	ON	OFF
Reserved	OFF	ON	OFF	ON	OFF	ON
KALATEL	ON	ON	OFF	ON	ON	OFF
Reserved	OFF	OFF	ON	ON	OFF	ON
Reserved	ON	OFF	ON	ON	OFF	ON
COP-1	OFF	ON	ON	ON	OFF	ON
Ultrak	ON	ON	ON	ON	OFF	ON

- b) DIP5 and DIP6 are used to select the baud rate, shown as following table (DIP7 and DIP8 are not used):

Baud Rate	Status of ID-CODE							
	DIP1	DIP2	DIP3	DIP4	DIP5	DIP6	DIP7	DIP8
2400bps					OFF	OFF		
4800bps					ON	OFF		
9600bps					OFF	ON		
19200bps					ON	ON		

- c) Some of the ID-CODE of the protocols are set as follows:

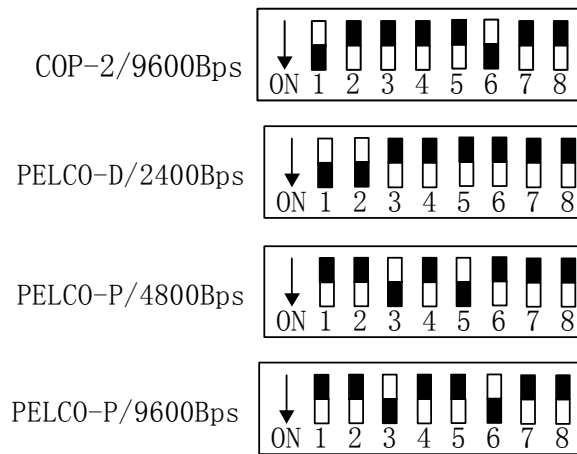

- d) **Switching control between speed dome and multiplexer:** The controller can be operated in two modes: Speed Dome and Multiplexer. When power supply is on it is operated on the default mode, namely, the Speed Dome. Press **[F3]** to make switch between two modes. When it is under the mode of the Multiplexer, you can control it via “Address Box”. At this time, the LCD will display “**Mulx Addr:001**”. Alternatively you can control it by pressing **[F3]** down until the LCD displays “**CONTROLLING MULX**”, then control the multiplexer by the RS-232 output of the keyboard. The RS-485 output of the keyboard cannot be used to control the multiplexer. When operation, please pay attention to the information on the LCD.

V. Operation of the Keyboard

- Select Address of the Speed Dome Camera: **[CAM]+[N]+[Enter]**
 Display: **Current CamID: 001**
 Description: N — No. of camera from 0 to 255
 Function: Select the address of the camera to be controlled. When the value N is in conformity with the address of the Speed Dome Camera, it will be under control.
- Set the Preset Position: **[PRESET]+[N]+[Enter]**
 Display: **Preset No: 001**
 Description: N — No. of preset position from 1 to 128.
 Function: Store current position and refer it as No. N position.
 Notice: Preset point set is using joystick before choice that need find a view bound.
- Call the Preset Position: **[CALL]+[N]+[Enter]**
 Display: **Call Number: 001**
 Description: N — No. of preset position from 1 to 128.
 Function: Transfer the camera to the position of No. N preset position.
- Cancel the Preset Position:**[PRESET]+[N]+[OFF]**
 Display: **Preset No: 001**
 Description: N — No. of preset position from 1 to 128.
 Function: Delete the No. N preset position stored.
- Set the Cruise Track (COP-2, PELCO-D, PELCO-P Available):
 - Enter the Status of Track Setting: **[SHOT]+[N]+ [ON]** (N: No. of track from 1 to 6).
 Display: **Track = 01 Sum = 06**
 Description: Track No.1 is currently setting, in which there are 6 preset points.
 - Edit Track: Press **[TELE]** to edit down page and press **[WIDE]** to edit up page. Each track involves 16 preset points and the running speed and the dwelling time of each preset position.
 Display: **No.: 01 Point: 001** Please Enter <1-64> → Description: The 1st preset position in the track is 001.

Display: Please Enter <1-8> → Description: The speed of the 1st preset point in the track is the 1st class.

Display: Please Enter <1-255> → Description: The dwelling time of the 1st preset point in the track is 4 seconds
:
:

- Speed Range: 1 to 8 Fixed 15rad / s for constant dome. the range of the dwelling time is: 1 to 255.
- When the No. N preset point is set as No. 0, then all preset points before the No. N preset point in the track will be valid however all numbers of preset points afterward and their speed and dwelling time shall be set as 0 automatically.
- After tracks are edited, press OFF to store and exit while push the joystick to exit without storage.

6. Run Cruise Track: **[SHOT]+[N]+ [Enter]**

Display:

Description: N — No. of the track from 1 to 6.

Function: Tour the No. N track and stop tour by pushing the joystick.

7. Stop Cruise Track: **[SHOT]+[N]+ [OFF]**

Display:

Description: N — No. of the track from 1 to 6.

Function: Stop the No. N track or stop tour by pushing the joystick.

8.. Auto Pan ON (Operation of PELCO-D and PELCO-P Protocols):

(1) Set the Starting Scan Position: Transfer the speed dome to the starting scan position, operation **[AUTO]+[ON]**

- ◆ Set the Ending Scan Position: Transfer the speed dome to the ending scan position, operation **[AUTO]+[OFF]**

Run Auto Pan: **[AUTO]+[ENTER]**

(2) Auto Pan operation takes the following parameters. You must set these parameters before using a Auto Pan command to begin the scan operation. You can use the scan Stop command or PT scan stop command to stop the scan. Setting scan condition:

- Auto Pan Position(First specify position, second specify position)
- Auto Pan Speed and Direction.

Note:

For COP-2 Protocol the way of operation is as follows:

[AUTO]+[P1]+[ON]+[P2]+[OFF]

Display:

Description: P1—— the starting scan No. of preset point from 1 to 128, which should be set already.

Display:

Description: P2—— the ending scan No. of preset point from 1 to 128, which should be set already.

- ◆ If P1 = P2 or P1 and P2 are coincided, the speed dome will make scan in range of 360°.

9. Stop Auto Pan: **[AUTO]+[OFF]** (only for COP-2 protocol)or push the joystick to stop scan.

15. Use the Joystick to control the speed dome camera:

You can use the speed joystick to control the Pan/Tilt direction and speed of the speed dome randomly. The speed of pan/tilt is decided by the angle of the joystick you operated (Figure 3). Change the tilting angle of the joystick you can adjust the speed evenly and the camera can be

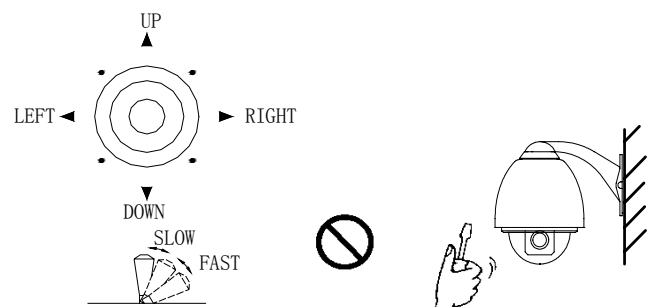

Figure 3

focused automatically in the course of scan to keep images being distinct.

16. In case error operation occurs, normal display will be recovered after “Error Operation” appears for 1 second.

VI. Installation and Connection:

Attention: Please read the operation manual of the keyboard and the speed dome carefully before connecting wires. Any incorrect connections can cause permanent damage of the device. When connecting wires, first switch off the power supply of all devices. The communication wires between devices should be shielded twisted cable. When installing cables they should be far away from high voltage lines or other possible interference circuits as can as possible.

1. The marking of wires of the transfer box (Figure 4)
2. Connections of the keyboard controller controlling multiple speed dome cameras (Figure 5)
3. Connections between the keyboard and the speed dome camera (Figure 6)
4. Connection Drawing between the keyboard and the multiplexer via the address box (Figure 7)
5. System Connection Drawing between the keyboard and the dome camera and the multiplexer (Figure 8)

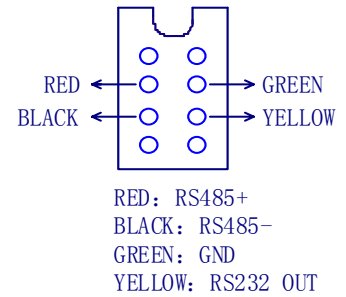

Figure 4

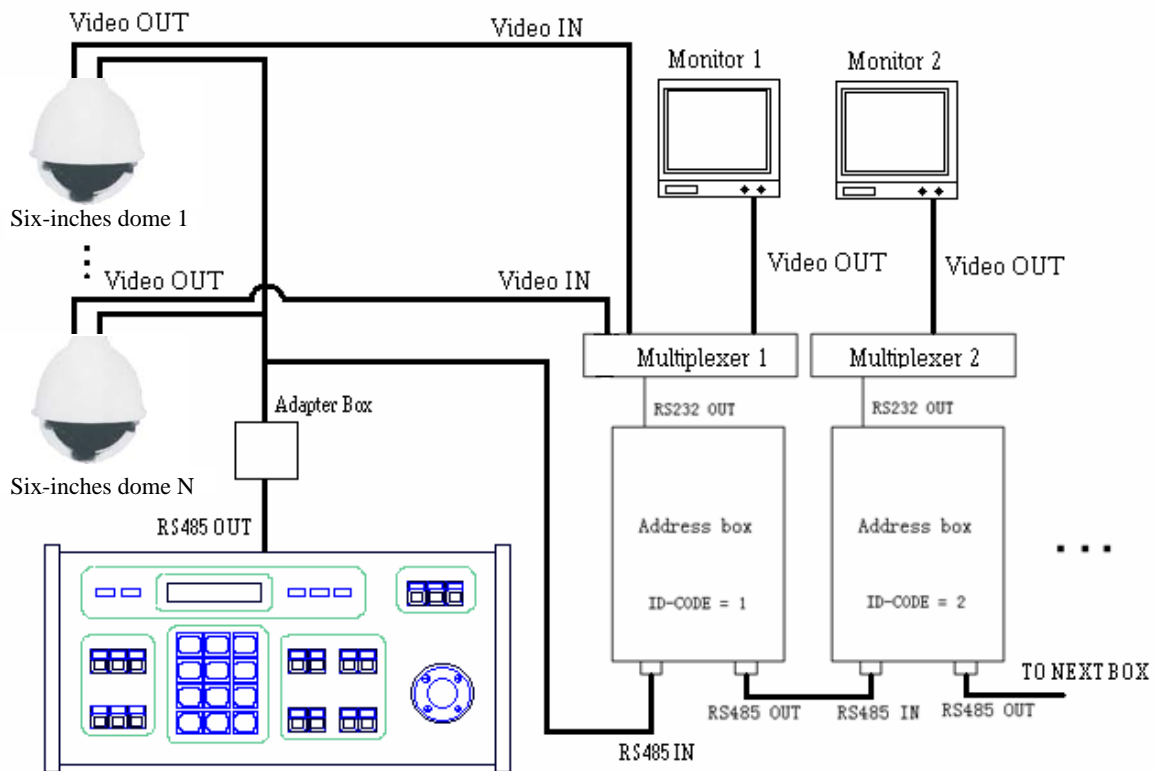

Figure 7

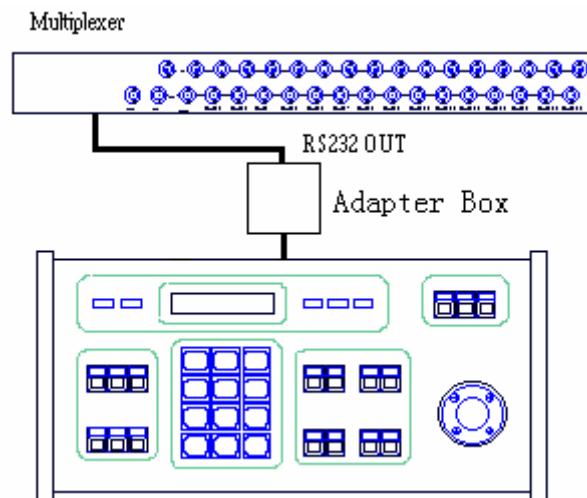

Figure 8

VII. Technical Specifications:

- ◆ Communication between Speed Dome Camera and Controller: Port to multi-port and half duplex function.
- ◆ Communication connector: RS-485.
- ◆ Baud Rate of Communication: Four baud rates i.e. 2400bps, 4800bps, 9600bps and 19200bps.
- ◆ Distance of Communication: 1200m in maximum
- ◆ Power Supply: DC12V/1A
- ◆ Size: 315 × 165 × 57 (mm)
- ◆ Weight: 2 Kg
- ◆ Number of controlled speed dome camera up to 32.

VIII. Points for Attention:

- ◆ Please read the operation manual of the keyboard carefully before using it.
- ◆ The operation manual is mainly focused on all functions of **PELCO-D**, **PELCO-P** and **COP-2** Protocols. For other different protocols, operations could be something different and those different parts will be listed on “**Supplementary Description of the Keyboard Controller**” in details.
- ◆ The keyboard takes DC12V power supply. Please confirm the voltage and polarity before the power supply is switched on.
- ◆ Do not place the keyboard under the rain or on wet place so as to avoid short circuit or electrical shock.
- ◆ As the keyboard is a sophisticated electronic device, you should never open the case so as to avoid the occurrence of trouble.
- ◆ The keyboard has integrated multiple protocols, and you are pleased to select correct protocol and the baud rate. When switching on power supply, take care of the selected protocol and the baud rate on the first screen.
- ◆ In case the keyboard controls the multiplexer, the operation of combination buttons is as follows: Press one button first, and press the other button after release the first one.
For example: When enter/exit setting of the menu (**Function + Zoom**), press **Function** button first, and press **Zoom** button after **Function** button is released. While use **Func** alone, please put it down until “Motion Detect OK” appears.
- ◆ When control the multiplexer through adapter box, select the multiplexer address:
N + CAM/ID (N: multiplexer address 1--128).
- ◆ In case the keyboard controls the multiplexer, select the camera (**1-16**): **N + Enter** N: channel Number (1--16).
- ◆ When the keyboard controls the multiplexer, please refer to concerned operation manual of the multiplexer.